



A Comprehensive Survey on UAV-based Data Gathering Techniques in Wireless Sensor Networks

Muhammad Aamir Khan^{1,*} and Fahad Farooq¹

¹Department of Electronic Engineering, Sir Syed University of Engineering and Technology, Karachi, Pakistan

Abstract

In the recent era of communication, wireless sensor networks (WSNs) emerged as a demanding area of study due to their communication capacity especially in the application of Internet of things (IoT). As the breadth and range of networks expand quickly, it becomes necessary to sense, transmit, and interpret the massive amount of data in IoT devices. WSN becomes even more beneficial and popular among the researchers when it integrates with unmanned aerial vehicles (UAVs) to increase the life span and establish a reliable communication between itself and Network Control Centre in an efficient way. Memory problems and network data transmission processing times are also addressed by this integration technique. In this paper, a large scale of data gathering techniques between WSN and UAV-controlled devices are addressed which will favor the research community to further enhance various design and many functional parameters like security, resource management, positioning and different processing techniques.

Keywords: wireless sensor network, internet of things, communication channel, unmanned aerial vehicle, network control centre, data gathering.

1 Introduction

The deployment of large scale Wireless Sensor Network (WSN) produces a great innovations and advancements in the field of networking, communication and material science technologies. Wireless Sensor Networks (WSNs) are playing vital role in many industrial applications like agriculture, environment monitoring, and smart metering and also in the healthcare fields [1]. The sensors requirements in WSN are based on durability, sustainability, cost effective and prolong life so that it can be beneficial and suitable for the optimized network. The area of application for WSN can be enormously increased by deploying unmanned aerial vehicle (UAV) and mobile agents (MA) in a distance of hundreds or thousands of kilometers. The presence of UAVs and MA's for the various data gathering methods in wide scale WSN environment are discussed in the literature. The deployment of the sensors in WSN depends on the type of application such as the structure using water, gas and oil channels, bridges, highways, and coastal line [2, 3].

Wireless Sensor Networks (WSNs) consists of huge amount of sensor nodes which are especially used for the data gathering techniques such as pressure monitoring, health care monitoring, target tracking, and fire detection. The collection of data from the



Academic Editor:

Feng Ding

Submitted: 16 October 2024

Accepted: 15 December 2024

Published: 16 January 2025

Vol. 2, No. 1, 2025.

10.62762/TIS.2025.790920

*Corresponding author:

✉ Muhammad Aamir Khan
maamirk@ssuet.edu.pk

Citation

Khan, M. A., & Farooq, F. (2024). A Comprehensive Survey on UAV-based Data Gathering Techniques in Wireless Sensor Networks. *IECE Transactions on Intelligent Systematics*, 2(1), 66–75.

© 2024 IECE (Institute of Emerging and Computer Engineers)

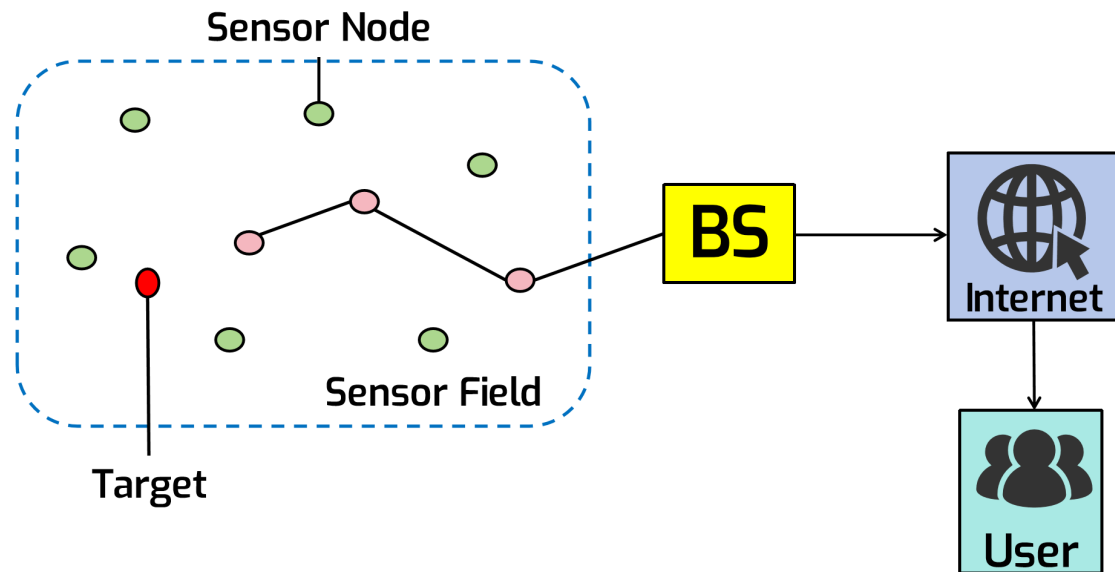

Figure 1. Basic Architecture of WSN.

environment can be achieved by the sensor nodes that include transceivers, transducers, and wireless interfaces. The sensor nodes are installed at remote distances to perform communication between the source and destination [4] by the help of considerable processing power, memory and battery life. The basic structure of the communication is depicted in Figure 1.

Wireless Sensor Network is a combination of various heterogeneous sensor nodes combined to gather the data by sensing the modifications in the surrounding such as noise level, pressure, temperature, humidity, and vibration of the objects. Generally, WSN possess no fixed architecture which may be deployed to all different categories due to limitations and restrictions.

The brief evolution in WSN is very helpful to understand its importance especially in advanced technologies, industrial applications, military applications, and large scale monitoring in the precise agriculture fields [4]. The first wireless network was developed by the United States Military in 1950s termed as Sound Surveillance System (SOSUS) to detect and track submarines [6]. This network comprises of hydrophones, acoustic sensors distributed in the Pacific and Atlantic oceans. This sensing design network is still alive and provides services to the military operations. The further developments made in the decade between 1960s to 1970s to design the hardware for the recent network. In 1980, United States Defense Advanced Research Projects Agency (DARPA) initiated the Distributed Sensor Network (DSN) to address the restrictions and limitations in deploying wireless sensor networks. The further transition phases [6] of WSN are characterized

as:

- UCLA Wireless Network Sensors
- NASA Sensors
- μ Adaptive Multi-domain Power Aware Sensors
- ZigBee integrated Sensors
- Center for Embedded Network Sensing

When cost effective sensors are integrated with the network, it enables the new applications like HVAC (heating, ventilation and air conditioning) control optimization and lighting inside the corridor of the buildings and homes. According to the energy report published in 2012, a significant amount of energy is wasted due to the absent of smart sensor system. The presence of HVAC and smart lighting systems provides the solution of this energy wastage by programming the timers at best optimum parameter and avoid the physical presence of humans.

The idea of joint collaboration of unmanned aerial vehicle and wireless sensor network (UAV-WSN) system for the purpose of data gathering, monitoring large scale regions, and surveillance becomes most popular and demanding in the era of telecommunication today [7]. The benefits of this collaboration emphasizes on accessibility, data gathering, broad area monitoring, increase mobility, and response time in emergency cases. The basic structure of this collaboration is shown in Figure 2 where the integrated monitoring system comprises of four main parts: Ground WSNs, GSM module, UAVs, and ground control stations (GCSs).

The primary objective of the UAV team is to gather data and capturing the images of the surface of respective coverage area where one or more structure of the WSNs deployed [8]. To accomplish the task, some limitations are needed to be addressed like path trajectory and length, energy consumption of the devices, and distance between UAV and WSN nodes. Recently, many studies and research have been considered especially for the joint collaboration of UAV- WSN system design with Internet of Things (IoT) applications for the long distance communication abilities and also provides the control mechanism for the cloud processing and data storage. The combination of entire UAV-WSN model is considered to be as autonomous multi-agent system

The emerging demand and novelty of the integrated unmanned aerial vehicle and wireless sensor network was introduced [9] for the data collection, control and analysis of some specialized applications. This idea presented a hierarchical structure related to the joint collaboration of UAV-WSN system model for crop monitoring in precision agriculture fields. This study also gives advantages for the efficient central monitoring to manage the workload and latency to achieve the optimization.

The aim and motivation of this survey paper is to evaluate the various data gathering techniques apply on UAV-WSN based systems in a joint collaboration which will be beneficial for the researchers to estimate the best and optimum solution for their required goals while comparing different explorations and algorithms of all the strategies. The best suited data collection technique is essential to overcome the barriers of uncertainties, complexities and different limitations. The efficient data gathering algorithm in large scale environment will certainly bring the accuracy, cost effectiveness and optimization in the system. The key contributions of this paper are:

- To analyze the performance and challenges faced under different strategies while extracting data collection techniques.
- To implement a large scale of data gathering techniques between WSN and UAVs controlled devices.
- To explore the findings and constraints of different data gathering techniques to further improve the performance parameters of the communication medium in a large scale environment to achieve network optimization.

The scheme of this paper has many sections, in which Section 1 provides the introduction of UAV-WSB based data gathering methods. Section 2 presents the state of art parameters for implementation of data collection techniques in a large scale networks. Section 3 reviews problem statement and proposed solutions of different scenarios of various data gathering algorithms. Section 4 discusses the latest advancements and developments in UAV-WSN based data gathering techniques. Section 5 presents conclusion and future recommendations to address the constraints of different data gathering schemes in a large scale environment.

2 State of Art

The effectiveness of data gathering techniques in the integrated joint collaboration of unmanned aerial vehicle and wireless sensor network (UAV-WSN) design model is one of the emerging state of the art solutions for wide area monitoring. With its growing scale of networks, a large amount of data collection schemes needed to be addressed in terms of sensing, processing and transmitting so Wang et al. [25] proposed Compressive data gathering (CDG) technique in wireless sensor network which addresses compressive sensing theory as a perfectly matched method for the data compressing and gathering in a large scale network. This study also proved that a compressible data vector could be recovered from its sparse random projections. Sparse random projections can be acquired through a sparse random projection matrix Φ which contains entries.

$$\Phi_{ij} = \sqrt{s} \int_{-1}^1 \left(1 - \frac{1}{s}\right) \quad (1)$$

where s is a constant to control the probability. Each Φ_{ij} equals nonzero with the probability $1/s$.

Air pollution in our environment becomes drastically increasing in an alarming rate which can severely damages the human health and also makes negative impact of economic effects especially on the urban cities across the world. Therefore, Polonelli et al. [24] introduced a method of centralized monitoring of atmospheric pollution concentration with great precision and accuracy. To accomplish the desired task, an autonomous unmanned aerial vehicle was used to measure the air pollution from a suitable height at a remote distance and transmit the data to the ground station wirelessly.

In future system design, wireless communication integrated with the joint collaboration of UAV-WSN

Pravija Raj et al. [10] proposed an effective data gathering technique termed as EDGO based on UAVs for the wireless sensor networks interacting with the obstacles. This novel work provides the joint collaboration of UAV-WSN approach for data collection especially in a 3D environment with the obstacles. The proposed method addresses the limitations of various parameters such as angle cost of the path, reduce the length, and reducing the energy consumption, delay, and various evolutionary functions.

Raj et al. [11] introduced an enhanced revolutionary protocol termed as Obstacle-aware data gathering in UAV (OaD-UAV) assisted WSN system to address different factors like delay in WSN data gathering, and energy efficiency. This approach examines the feasibility of UAV path selection and changes in the angle in a complex obstacles-present environment. This scheme reveals the benefits of path cost, efficiency of data collection, network lifetime, and energy efficiency.

Nazib et al. [12] proposed an innovative UAV based data collection technique to address the issues of unplanned trajectory for the remote areas. The proposed study focused the non behavioral effects of the unplanned trajectory of the UAVs on the sensor nodes. The study shows that the proposed work is also feasible and beneficial in the energy conservation and large amount of data collection in the remote regions in an efficient way.

Saxena et al. [13] proposed a method on the trajectory of the UAVs which is recommended as a compatible path that can able to include the entire cluster heads in the wireless sensor networks. This research work tends to estimate the path selection in polynomial time. The need of routing protocol is eliminated if the sensor nodes are sent directly to the UAV. The proposed technique shows that the overall coverage of the sensor nodes is improved with reduced delay and minimizes data loss while comparing with single hop and multiple hop routing protocols of WSN.

4 Advancements of Data Gathering Schemes in UAV-WSN Along with Its Variants

The main idea of this research study is to analyze the different data collecting methods applied on UAV-WSN related systems as a combined collaboration which will be suitable in the various fields like reliable and energy efficient system, precision agriculture, healthcare architecture, remote sensing network, precision adjustable trajectory

planning scheme, smart cities solutions, and weather and air pollution monitoring systems. The ideal data gathering technique is important for the researchers to address the challenges, complexities and restrictions. The efficient data collecting algorithm in wide scale network will bring accuracy, reliability, optimization, and cost effectiveness in the network. The comprehensive analysis of some advanced and emerging data collecting techniques are organized and gathered in Table 1 to evaluate the network performance parameters in terms of effective data gathering algorithms. Year wise analysis of such algorithms is as follows:

In 2019, Ali et al. [14] proposed an algorithm in wireless sensor networks to address the problems of data collection and the controlling of UAVs in terms of altitude. The proposed study verifies that the data delivery becomes steady when the UAV achieve its required height having constant speed. Bithas et al. [15] provided the detailed and comprehensive study of various research works in which machine learning techniques are involved in UAV related communications for the various functional and design aspects like resource management, channel modeling, positioning, and security. Cermakova et al. [16] proposed an efficient use of unmanned aerial vehicle for the monitoring of changes of small water areas and the nearby land coverage areas. The study also addressed the effective monitoring of small water body aligned with the vegetation spectral indices that are observed from the available electromagnetic spectrum. Tsouros et al. [17] proposed an article for reviewing the most advanced and recent applications of UAV based precision agriculture. In this study, the outcomes of some data acquisition techniques and technologies were addressed in terms of aerial imagery in farming operations and also reflecting the benefits and limitations of each method. Ullah et al. [18] introduced a protocol based on the concept of wake-up radio communication between multiple BANs and UAV in terms of performance parameters like priority allocations to the gateways, throughput and delay. The open research problems and limitations that are effective for the development of advanced protocol especially for the UAV favored data acquisition in smart healthcare networks are also addressed in this study. Kalaivanan et al. [19] presented a novel clustering algorithm where the UAV data collector is used to gather the desired information from the cluster heads that transmits the collected information to the base station which will

Table 1. Comparative analysis of UAVs based data gathering techniques in WSN.

Year	Ref	Paper Title	Algorithm applied	Application	Major goals	Key Findings	Limitations
2019	[14]	UAV Based Data Gathering in Wireless Sensor Networks	WSN data gathering with altitude control	Unmanned Aerial Vehicles (UAVs)	Speed observation with or without delay	Effective data gatherings from altitude control UAVs	Altitude control and alignment of UAV may be explore
2019	[15]	A Survey on Machine-Learning Techniques for UAV-Based Communications	Machine Learning (ML) framework	Unmanned Aerial Vehicles (UAVs)	Comparison of vast amount of data received from single source to multiple source	UAV based ML analysis for some functional and design aspects	ML detection techniques can be further combined with other existing detection techniques
2019	[16]	Calculation of Visible Spectral Indices from UAV Based Data: Small Water Bodies Monitoring	Smart water body monitoring	Unmanned Aerial Vehicles (UAVs)	Indices of NEXG and other protocols are compared	Monitoring of on demand small water bodies and nearby land coverage areas using reduced cost UAVs	regional state administration can use UAVs for cost effective changes for traditional data sources
2019	[17]	A Review on UAV-Based Applications for Precision Agriculture	Data acquisition methods and technologies	Internet of Things (IoT) devices	Vegetation indices, ML techniques and Photogrammetric mechanism are compared	Analysis of accurate precision agriculture on UAV based applications	UAV based IoT technology can be used in future for remote sensing in precision agriculture
2019	[18]	UAV-enabled Healthcare Architecture: Issues and Challenges	Wakeup communication	Unmanned Aerial Vehicles (UAVs) architecture	UAVs and BAN	Data collection from multiple BANs using Wakeup radio protocol design	IoT can transform smart health care systems in future
2019	[19]	Unmanned Aerial Vehicle based Reliable and Energy Efficient Data Collection from Red Alerted Area using Wireless Sensor Networks with IoT	REEDCM	Internet of Things (IoT) devices	Comparison b/w REEDCM, MBC, SEECH, and NEEC	Proposed protocol support better performance parameters in term of optimization and reliability	REEDCM performance can be analyzed using multimedia packets such as image, audio and video
2019	[20]	Mini-Unmanned Aerial Vehicle-Based Remote Sensing	UAV-based remote sensing	Mini Unmanned Aerial Vehicles (UAVs)	Comparison of UAV with manned aircraft satellite	Proposed work address the recent trends, applications, and remote sensing community including data processing	UAV based data processing technologies based UAV-RS can be targeted in the future studies
2020	[21]	A Survey of Key Issues in UAV Data Collection in the Internet of Things	UAV related data gathering technique in IoT	UAV based Complex geographical environments	Comparison of data gathering in terms of SNs deployment, and path planning	Analysis of UAV path planning, and effects of UAV configuration have introduced	Trained system model can be achieved with the promotion of big data
2020	[22]	Capacity of Unmanned Aerial Vehicle Assisted Data Collection in Wireless Sensor Networks	Data collection via movable sink	Unmanned Aerial Vehicles (UAVs)	Single UAV Multiple UAVs	Path planning algorithms, average execution time and per node capacity derived in both single and multiple UAVs	Execution time and per node capacity can be further measured in WSN based data collection
2020	[23]	Priority-Based Data Collection for UAV-Aided Mobile Sensor Network	PCDFS	multiple UAV based WSN	Balance algorithm b/w multi-UAVs	Proposed study provides better communication between multiple nodes and UAVs I collision free environment	Backhaul dimensioning can be addressed in the future
2020	[24]	A Flexible, Low-Power Platform for UAV-Based Data Collection from Remote Sensors	Ultra-wide band technology	Unmanned Aerial Vehicles (UAVs) Wireless sensors	Comparison b/w two localization systems in terms of ATWK and coil coupling	Low power wireless sensor design model integrating with UAVs in hazardous and extreme environments	Flexibility and interoperability of this hardware design can be further improved as open source
2020	[25]	An Intelligent UAV based Data Aggregation Strategy for IoT After Disaster Scenarios	IDAS	Internet of Things (IoT)	Performance of IDAS compared with data aggregation task and reinforcement learning	Proposed technique achieved tradeoff b/w aggregation ratio and energy cost	IDAS can be further analyzed in hazardous and complex environment
2020	[26]	Performance Analysis and Optimization for the MAC Protocol in UAV-based IoT Network	Heterogeneous network communication	UAVs IoT network	Analysis of design model compared with CSMA/CA protocol	Proposed model provides accuracy and reliability of CSMA/CA protocol in UAV aided system	Proposed work can be further evaluated with other existing protocols
2021	[27]	UAV-Based Remote Sensing Applications for Bridge Condition Assessment	UAV bridge condition monitoring	Unmanned Aerial Vehicles (UAVs)	Joint collaboration of NDT-UAV are compared	Performance of UAV equipped with NDT are evaluated including visual imaging devices, infrared sensors and other sensors	AI and emerging IoT techniques can be applied for further data collection and processing
2021	[28]	A precision adjustable trajectory planning scheme for UAV-based data collection in IoT	Precision adjustable trajectory planning (PATP) technique	Internet of Things (IoT) nodes	Comparison b/w PATP and OD-PATP	Proposed study provides more sophisticated data collection methods by using trajectory planning	This work can be further applied on complex systems like Multi-UAV task scheduling, and energy optimization techniques
2021	[29]	UAV-based framework for effective data analysis of forest fire detection using 5G networks: An effective approach towards smart cities solutions	Effective data analysis of forest fire detection	Unmanned Aerial Vehicles (UAVs)	Comparison analysis b/w throughput, maximum coverage and network delay	Experimental results provides better energy efficiency among UAV communication	In future, Mapping approach can be applied to the proposed work for regular monitoring
2022	[30]	A Survey of Compressive Data Gathering in WSNs for IoT	Comprehensive data gathering (CDG) techniques	Wireless sensor networks (WSN)	Proposed technique is compared w.r.t routing protocol and clustering schemes	Proposed study provides effective results in routing protocol, clustering schemes and combination of both parameters with other technologies	CDG algorithm can be further improved by joint and global optimization techniques
2023	[31]	A survey of UAV-based data collection: Challenges, solutions and future perspectives	Data collection and analysis	Unmanned Aerial Vehicles (UAVs)	Data analysis and performance parameters	Monitoring , coverage, data offloading and relay information are key contributions	Multi UAVs may be used in future for efficient data analysis
2023	[32]	Data Acquisition Control for UAV-Enabled Wireless Rechargeable Sensor Networks	MDT's for all nodes	Wireless sensor networks (WSN)	Mitigate energy imbalance and reduce the number of hops	Proposed scheme observed reduced energy depletion, increased network connectivity, and the amount of data collected at the sink node.	Increasing efficiency in the energy utilization may be addressed in future studies.
2024	[33]	UAV-assisted data collection for wireless sensor networks with dynamic working modes	Heterogeneous sensor nodes	Unmanned Aerial Vehicles (UAVs)	Data collection constraints	Proposed work presented an effective method for energy optimization.	Machine learning techniques may be applied to improve energy optimization.

share the information to the end users via internet. The simulation results shows that the proposed algorithm is best suited for the network performance especially in terms of throughput, average delay, residual energy and packet delivery ratio. Xiang et al. [20] presented a survey analysis of latest developments and future aspects of UAVs for remote sensing community. The core challenges and technologies of remote sensing data processing on UAVs and some future recommendations of recent UAV-RS were also discussed which can be beneficial for the remote sensing researchers.

In 2020, Yang et al. [21] proposed the key technologies of UAV based data gathering technique deployed in Internet of Things. In this study, the problems of SNs deployment, the effects and analysis of UAV configuration and the autonomous navigation were addressed. Wei et al. [22] presented the analysis for the capacity of UAV supported data collection in WSN provided a guideline for the optimization parameters in the existence of UAVs. In this study, the charging points for UAVs are located around the service area where all the sensors are distributed. Ma et al. [23] proposed the data gathering technique in multiple UAVs supported many WSNs design model. In this work, the proposed algorithm's performance is analyzed through the real experiments and simulations when the topological structure of the network is changing dynamically due to the movements of sensor nodes and UAVs. Polonelli et al. [24] presented a design and characterization of a recent low energy hardware infrastructure to integrate wireless sensor network and unmanned aerial vehicle. This joint integration overcomes the maintenance and data collection problems for the monitoring in remote, and complex environments. In this study, the results were supported by the comprehensive analysis and extensive modeling for the application flexibility, and reliability in a broad variety of sensors. Wang et al. [25] proposed a smart UAV based data aggregation strategy to address the disaster occurrence in Internet of Things. All the desired information is aggregated by the UAV deployment towards the rescue headquarter. In this proposed study, the simulation results indicate the rising aggregation ratio and reduced energy cost of proposed technique as compared to the existing strategies. Li et al. [26] presented a novel design model to deal with the communication heterogeneous structure in the network. This study proposed an air ground network where the multiple UAVs flies at a suitable height to gather the useful data

from the IoT devices located in the field in a 2D plane manner by using CSMA/CA protocol. The main purpose of this protocol is to allocate the time resources to the end users adaptively among the IoT devices located in nearby clusters. Feroz et al. [27] presented a comparative and detailed review study addressing the application of UAVs especially in the areas like remote monitoring methods such as visual imagery, LiDAR, infrared thermography, and bridge condition monitoring. This study also provides detailed comparison of joint collaboration of NDT-UAV techniques, and the bridge inspection facilities. Wang et al. [28] proposed a precision adjustable trajectory planning method that estimate the area of communication related to stratified grid technique and reduce the traveling trajectory by limiting the data collection of the UAVs in order to activate the tradeoff between calculated precision and execution time. The results show that the proposed scheme achieved 15% reduction in the amount of visiting points and trajectory length was shortened to 45% by OD-PATP method. Sharma et al. [29] proposed an idea of using unmanned aerial vehicle for data collection of those areas where the fire detection needs to be detected on urgent basis. This study is very essential for detecting the fires especially in the remote areas like forests and immediately reporting the event to the centralized control room in the smart cities by using UAV-WSN systems and 5G assisted technologies.

In 2022, Wang et al. [30] proposed Compressive data gathering (CDG) technique in wireless sensor network which addresses a compressive sensing theory as a perfectly matched method for the data compressing and gathering in a large scale network. Air pollution in our environment becomes drastically increasing in an alarming rate which can severely damages the human health and also makes negative impact of economic effects especially on the urban cities across the world.

In 2023, Messaoudi et al. [31] presented the key contributions like monitoring, coverage, data offloading and relay information. Minimization of data collection (DC) delay, powering IoT devices, and efficient delivery of collected data are also addressed in the proposed study. Yoon et al. [32] proposed a scheme that observed reduced energy depletion, increased network connectivity, and the amount of data collected at the sink node.

In 2024, Nguyen et al. [34] presented a study that provides an effective method for energy optimization. In this work, to protect the sensor nodes with low

RE, we investigate dynamic working modes for sensor nodes which are determined by their RE and an introduced energy threshold.

5 Conclusion

The effective and efficient data collection techniques is very crucial for wireless sensor networks especially in the broader aspects of human health monitoring, precision agriculture, accurate farming, temperature monitoring, pressure monitoring, target tracking, latest fire detection methods, evaluation of network performance parameters, and multi-purpose tasks by the researchers. Similarly, the UAV based data gathering techniques integrated with various smart sensors can reduce the cost of large scale searching network and achieves better efficiency and optimization by reducing the workloads of the end users. This survey analysis also focuses on the latest upcoming trends of compressive data gathering algorithms in wireless sensor network which addresses the limitations and restrictions for effective data collection in a large scale network. This study can also be contributed into many areas of network performance parameters, monitoring tools and optimization related matters of various WSN applications. The Researchers can be focused to design those data gathering techniques which would be helpful to reduce the various types of pollutions from our environment in order to achieve better climate for the efficient way of attaining sustainable development goals developed by united nation. Future research in energy efficient data gathering, machine learning and AI based data analysis, and security can help to optimize the use of UAVs in wireless sensor networks.

Conflicts of Interest

The authors declare no conflicts of interest.

Funding

This work was supported without any funding.

References

- [1] Mainetti, L., Patrono, L., & Vilei, A. (2011, September). Evolution of wireless sensor networks towards the internet of things: A survey. In *SoftCOM 2011, 19th international conference on software, telecommunications and computer networks* (pp. 1-6). IEEE.
- [2] Riva, G. G., & Finochietto, J. M. (2012, June). Pheromone-based in-network processing for wireless sensor network monitoring systems. In *2012 IEEE International Conference on Communications (ICC)* (pp. 6560-6564). IEEE. [CrossRef]
- [3] Jawhar, I., Mohamed, N., & Al-Jaroodi, J. (2015, June). UAV-based data communication in wireless sensor networks: Models and strategies. In *2015 International conference on unmanned aircraft systems (ICUAS)* (pp. 687-694). IEEE. [CrossRef]
- [4] Singh, A. P., Luhach, A. K., Gao, X. Z., Kumar, S., & Roy, D. S. (2020). Evolution of wireless sensor network design from technology centric to user centric: an architectural perspective. *International Journal of Distributed Sensor Networks*, 16(8), 1550147720949138. [CrossRef]
- [5] Majid, M., Habib, S., Javed, A. R., Rizwan, M., Srivastava, G., Gadekallu, T. R., & Lin, J. C. W. (2022). Applications of wireless sensor networks and internet of things frameworks in the industry revolution 4.0: A systematic literature review. *Sensors*, 22(6), 2087. [CrossRef]
- [6] Ray, C. A. CONSIDERATIONS AND CHALLENGES IN SILENCING SUBMARINES.
- [7] Popescu, D., Dragana, C., Stoican, F., Ichim, L., & Stamatescu, G. (2018). A collaborative UAV-WSN network for monitoring large areas. *Sensors*, 18(12), 4202. [CrossRef]
- [8] Popescu, D., Stoican, F., Stamatescu, G., Ichim, L., & Dragana, C. (2020). Advanced UAV-WSN system for intelligent monitoring in precision agriculture. *Sensors*, 20(3), 817. [CrossRef]
- [9] Popescu, D., Stoican, F., Ichim, L., Stamatescu, G., & Dragana, C. (2019, September). Collaborative UAV-WSN system for data acquisition and processing in agriculture. In *2019 10th IEEE International Conference on Intelligent Data Acquisition and Advanced Computing Systems: Technology and Applications (IDAACS)* (Vol. 1, pp. 519-524). IEEE. [CrossRef]
- [10] Pravija Raj, P. V., Khedr, A. M., & Al Aghbari, Z. (2022). EDGO: UAV-based effective data gathering scheme for wireless sensor networks with obstacles. *Wireless Networks*, 28(6), 2499-2518. [CrossRef]
- [11] Raj, P. P., Khedr, A. M., & Aghbari, Z. A. (2023). An enhanced evolutionary scheme for obstacle-aware data gathering in uav-assisted wsns. *Journal of Ambient Intelligence and Humanized Computing*, 14(12), 16299-16311. [CrossRef]
- [12] Nazib, R. A., Bouk, S. H., Mir, Z. H., & Ko, Y. B. (2022, January). Unplanned UAV Trajectory-based Data Collection in Large-scale Sensor Networks. In *2022 International Conference on Information Networking (ICOIN)* (pp. 372-377). IEEE. [CrossRef]
- [13] Saxena, K., Gupta, N., Gupta, J., Sharma, D. K., & Dev, K. (2022). Trajectory optimization for the UAV assisted data collection in wireless sensor networks. *Wireless Networks*, 28(4), 1785-1796. [CrossRef]
- [14] Ali, Z. A., Masroor, S., & Aamir, M. (2019). UAV based data gathering in wireless sensor networks. *Wireless Personal Communications*, 106, 1801-1811. [CrossRef]
- [15] Bithas, P. S., Michailidis, E. T., Nomikos, N.,

- Vouyioukas, D., & Kanatas, A. G. (2019). A survey on machine-learning techniques for UAV-based communications. *Sensors*, 19(23), 5170. [CrossRef]
- [16] Cermakova, I., Komárková, J., & Sedlak, P. (2019, June). Calculation of visible spectral indices from UAV-based data: small water bodies monitoring. In *2019 14th Iberian Conference on Information Systems and Technologies (CISTI)* (pp. 1-5). IEEE. [CrossRef]
- [17] Tsouros, D. C., Bibi, S., & Sarigiannidis, P. G. (2019). A review on UAV-based applications for precision agriculture. *Information*, 10(11), 349. [CrossRef]
- [18] Ullah, S., Kim, K. I., Kim, K. H., Imran, M., Khan, P., Tovar, E., & Ali, F. (2019). UAV-enabled healthcare architecture: Issues and challenges. *Future Generation Computer Systems*, 97, 425-432. [CrossRef]
- [19] Kalaivanan, K., & Bhanumathi, V. (2019). Unmanned Aerial Vehicle based Reliable and Energy Efficient Data Collection from Red Alerted Area using Wireless Sensor Networks with IoT. *J. Inf. Sci. Eng.*, 35(3), 521-536.
- [20] Xiang, T. Z., Xia, G. S., & Zhang, L. (2019). Mini-unmanned aerial vehicle-based remote sensing: Techniques, applications, and prospects. *IEEE geoscience and remote sensing magazine*, 7(3), 29-63. [CrossRef]
- [21] Yang, X., Fu, S., Wu, B., & Zhang, M. (2020, August). A survey of key issues in UAV data collection in the Internet of Things. In *2020 IEEE Intl Conf on Dependable, Autonomic and Secure Computing, Intl Conf on Pervasive Intelligence and Computing, Intl Conf on Cloud and Big Data Computing, Intl Conf on Cyber Science and Technology Congress (DASC/PiCom/CBDCom/CyberSciTech)* (pp. 410-413). IEEE. [CrossRef]
- [22] Wei, Z., Chen, Q., Liu, S., & Wu, H. (2020). Capacity of unmanned aerial vehicle assisted data collection in wireless sensor networks. *IEEE Access*, 8, 162819-162829. [CrossRef]
- [23] Ma, X., Liu, T., Liu, S., Kacimi, R., & Dhaou, R. (2020). Priority-based data collection for UAV-aided mobile sensor network. *Sensors*, 20(11), 3034. [CrossRef]
- [24] Polonelli, T., Qin, Y., Yeatman, E. M., Benini, L., & Boyle, D. (2020). A flexible, low-power platform for UAV-based data collection from remote sensors. *IEEE Access*, 8, 164775-164785. [CrossRef]
- [25] Wang, X., Hu, J., & Lin, H. (2020, September). An intelligent UAV based data aggregation strategy for IoT after disaster scenarios. In *Proceedings of the 2nd ACM MobiCom Workshop on Drone Assisted Wireless Communications for 5G and beyond* (pp. 97-101). [CrossRef]
- [26] Li, B., Guo, X., Zhang, R., Du, X., & Guizani, M. (2020). Performance analysis and optimization for the MAC protocol in UAV-based IoT network. *IEEE Transactions on Vehicular Technology*, 69(8), 8925-8937. [CrossRef]
- [27] Feroz, S., & Abu Dabous, S. (2021). Uav-based remote sensing applications for bridge condition assessment. *Remote Sensing*, 13(9), 1809. [CrossRef]
- [28] Wang, Z., Tao, J., Gao, Y., Xu, Y., Sun, W., & Li, X. (2021). A precision adjustable trajectory planning scheme for UAV-based data collection in IoTs. *Peer-to-Peer Networking and Applications*, 14, 655-671. [CrossRef]
- [29] Sharma, A., & Singh, P. K. (2021). UAV-based framework for effective data analysis of forest fire detection using 5G networks: An effective approach towards smart cities solutions. *International Journal of Communication Systems*, e4826. [CrossRef]
- [30] Wang, X., & Chen, H. (2022). A survey of compressive data gathering in WSNs for IoTs. *Wireless Communications and Mobile Computing*, 2022(1), 4490790. [CrossRef]
- [31] Messaoudi, K., Oubbati, O. S., Rachedi, A., Lakas, A., Bendouma, T., & Chaib, N. (2023). A survey of UAV-based data collection: Challenges, solutions and future perspectives. *Journal of network and computer applications*, 216, 103670. [CrossRef]
- [32] Yoon, I. (2023). Data Acquisition Control for UAV-Enabled Wireless Rechargeable Sensor Networks. *Sensors*, 23(7), 3582. [CrossRef]
- [33] Chen, J., & Tang, J. (2024). UAV-assisted data collection for wireless sensor networks with dynamic working modes. *Digital Communications and Networks*, 10(3), 805-812. [CrossRef]
- [34] Nguyen, M. T., Nguyen, C. V., Do, H. T., Hua, H. T., Tran, T. A., Nguyen, A. D., ... & Viola, F. (2021). Uav-assisted data collection in wireless sensor networks: A comprehensive survey. *Electronics*, 10(21), 2603. [CrossRef]



Muhammad Aamir Khan received his Bachelor's degree in Electronic Engineering from Sir Syed University of Engineering and Technology, Karachi, Pakistan, in March 2008. He is also completed his Master's degree in Electronics specialization in Telecommunication from Sir Syed University of Engineering and Technology in March 2013. He is currently pursuing a PhD degree in Electronic Engineering at the Department of Electronics Engineering from Sir Syed University of Engineering and Technology. Recently, he has successfully defended his research proposal titled as Maneuver Control of Swarm: A Multitasking LoRa Network based Reinforcement Learning focusing on Energy efficiency, optimized bandwidth utilization and effective path routing. (Email: maamirk@ssuet.edu.pk)



Fahad Farooq is a dedicated professional with a strong background in Electronic and Telecommunication Engineering. He earned his Bachelor's degree in Electronic Engineering from Sir Syed University of Engineering and Technology (SSUET) in 2008, followed by a Master's degree in Telecommunication Engineering from Hamdard University in 2012. His research interests lie in the fields of control systems and automation, with a particular focus on Wireless Sensor Networks (WSNs). Fahad has contributed to the academic community through several research publications. Notable among these are his works on real-time border monitoring systems using WSNs, grid-cluster size calculations in wireless sensor networks, and an online gas pipeline monitoring system integrated with Android applications. These contributions highlight his expertise in designing efficient and innovative solutions for complex telecommunication and control challenges. (Email: ffarooq@ssuet.edu.pk)